

# BESPOKE STORIES

BLACK TIE





The smallest details make the biggest difference: they are the ones which make the real difference. Black Tie has a history of devoting great attention to all details, to the careful study and selection of materials, and the refined/special design which distinguishes its brand.

It is above all, and thanks to the painstaking attention given to even the smallest of details, that Black Tie has become a successful brand with a promising future.

Pier Luigi Frighetto the founder of Black Tie, has dedicated over thirty-five years of experience and passion to the production of upholstery. Blessed with an inquisitive mind and tireless researcher, this eclectic entrepreneur transmits through Black Tie his idea of elegance, luxury and comfort. Carefully selected International showrooms are among the few exclusive partners selected for this project.

These partners, are strategically located, share a vision of absolute exclusivity. Fine taste is foremost, while never being ostentatious.

Velvets, printed textiles, walnut wood and woven leather. Metal finishing, for articles with golden or bronze colored accents. A sophisticated collection, designed for environments characterized by a sober but refined elegance.

Environments where the concept of luxury is above all connected to "Living Well".

The Veneto region, the birthplace and land of our founder, forms the perfect frame to the story of each and every piece of this collection.

Sofas, poufs and comfortable armchairs, tables and lamps.

Each product is naturally suited to its collocation in private contemporary Wunderkammer hidden in the Vicentine hills.

Protagonists together with the products, the rooms of one of the most wonderful projects of Palladio: the Venetian Villas, the perfect scenography for this collection. The air is filled with the magical atmosphere of homes rich in history, perfect stage settings where a gentle sumptuousness embraces who enters.

Timeless ambients, where the contemporary naturally marries the past while enhancing both while respecting their uniqueness.

Each and every object is chosen to tell something, each detail to create a greater image.

Always inspired by an ideal of timeless beauty, Black Tie commits itself to render each and every object unique: each seat is rigorously made by hand and controlled in every minimal detail, and with very limited quantities. Each piece is numbered and accompanied by a passport which describes every single detail, because as we know, it is always the smallest detail that determines the true difference.

"Home is the resort  
Of love, of joy, of peace, and plenty; where  
Supporting and supported, polished friends  
And dear relations mingle into bliss".

*James Thomson*

-  
**STORY**  
01

































House or home, what matters are details  
(details matter)

-  
STORY  
02







Levante sofa (t.d. pag. 215), Savoi armchair (t.d. pag. 259), Milton coffee table (t.d. pag. 301), Elliot Plus side table (t.d. pag. 293), Tommi console (t.d. pag. 313), Tommi pouf (t.d. pag. 331), Elliot side tables (t.d. pag. 289), Nadine table lamps (t.d. pag. 343)































Some places you never really go away from.  
Places where you know you must go back,  
places you must recognize yourself.

-

STORY  
03





















A home is a part of our identity. Peace, tranquility, silence or music, a cigar and our favorite whiskey: home is where we find all that we need.

-  
STORY  
04







Island sofa (t.d. pag. 207), Samuel coffee table (t.d. pag. 307), Tommi consolle (t.d. pag. 313), Olivia bench (t.d. pag. 323), Elliot side tables (t.d. pag. 289), Nadine lamp (t.d. pag. 343).



























Surrounding yourself with beauty, searching for the difference in details that for others might be insignificant and which instead for you, are home.

-

STORY  
05







Camillo sofa (t.d. pag. 189), Tao side table (t.d. pag. 311), Elliot coffee table (t.d. pag. 289), Giulia armchair (t.d. pag. 253), Elliot Plus side table (t.d. pag. 293), Tosca floor lamp (t.d. pag. 347).



























When you are unhappy, return to the place that you love the most. He differently from other people always has something to tell you, and will always find a way to console you.

-  
STORY  
06













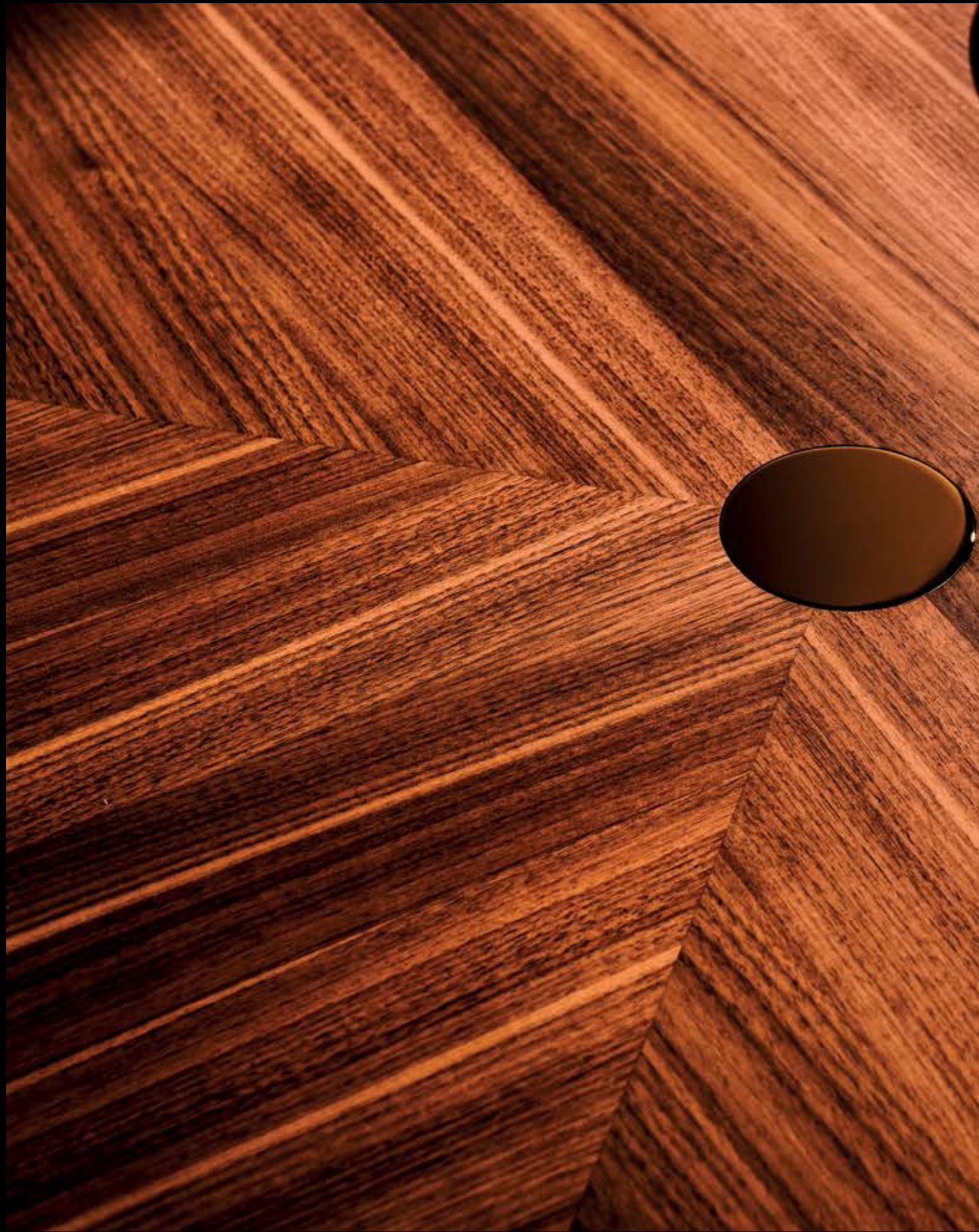















To feel home should signify to feel protected from all fears, from all injuries doubts or disagreements, like a shelter.

-  
STORY  
07







Dante sofa (t.d. pag. 195), Hugo coffee table (t.d. pag. 297), Tommi side table (t.d. pag. 313), Tao side table (t.d. pag. 311), Anic armchair (t.d. pag. 243),  
Theima lamp (t.d. pag. 345).































To have time nowadays is luxury.  
Time to sit, breathe and dedicate time to those we  
love, and to those who make us happy... It is the  
small things that can make a day different,  
or change an entire life.

-  
STORY  
08





















Each choice tells who we are.  
Every object is part of us: home is where we have  
our heart, home is where we write our life's story.

-  
STORY  
09





























The best part of leaving is knowing that we will return: as soon as we enter, that familiar perfume of books, furniture and people that we love. To return is to recognize that unique scent: the perfume of home.

-

STORY

10







Martin sofa (t.d. pag. 223), Pablo coffee table (t.d. pag. 305), Frisè armchair (t.d. pag. 249), frisé footrest (t.d. pag. 249), Tommi side table (t.d. pag. 313),  
Thelma table lamp (t.d. pag. 345).































**"That is my home of love"**

*William Shakespeare*

-

**STORY**

11









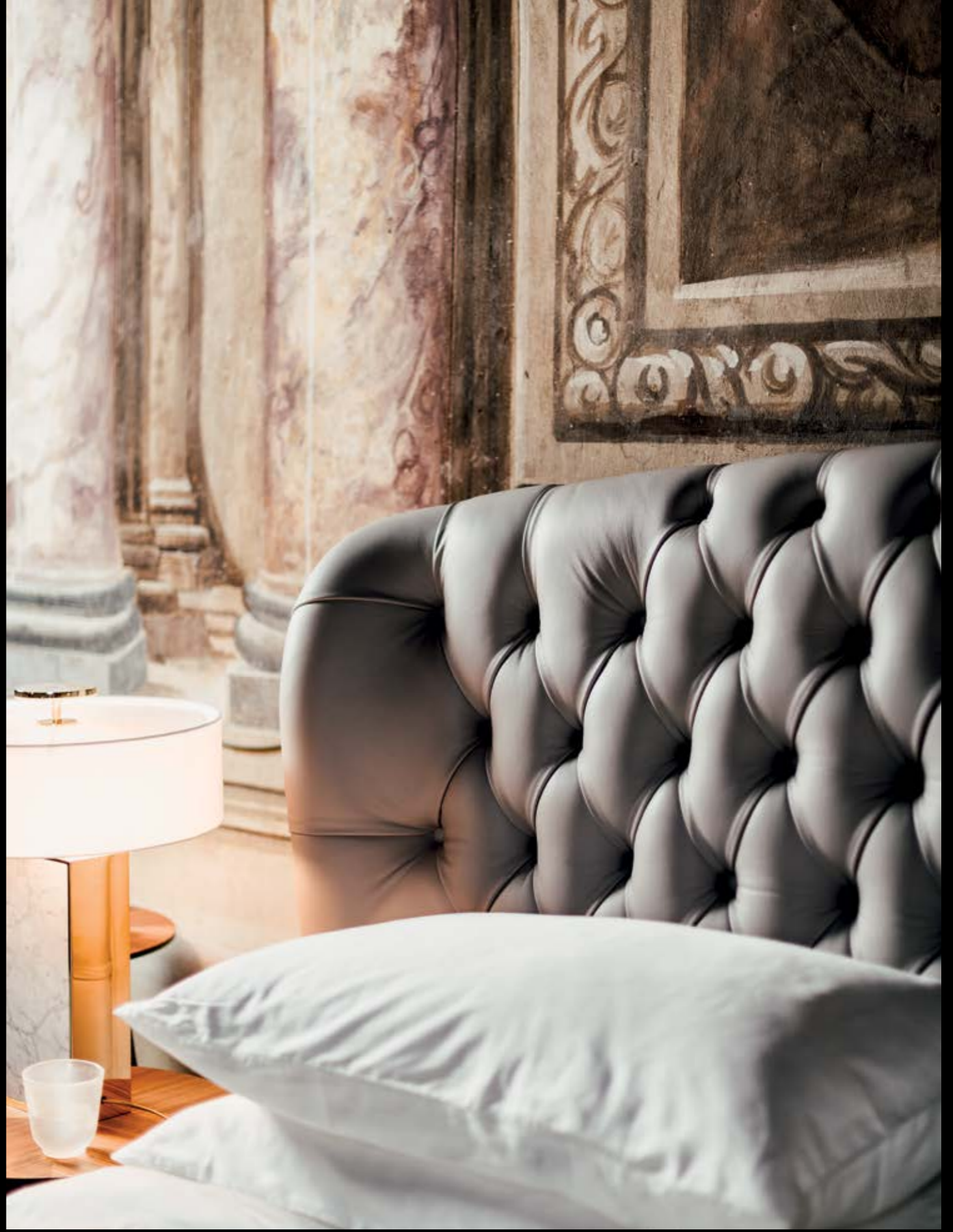



































**technical data**

|                                   |            |
|-----------------------------------|------------|
| <b>sofas</b> _____                | <b>177</b> |
| <b>armchairs</b> _____            | <b>239</b> |
| <b>chairs and stools</b> _____    | <b>265</b> |
| <b>dining tables</b> _____        | <b>279</b> |
| <b>coffee tables</b> _____        | <b>287</b> |
| <b>ottomans and benches</b> _____ | <b>317</b> |
| <b>beds</b> _____                 | <b>333</b> |
| <b>lighting</b> _____             | <b>337</b> |
| <b>accessories</b> _____          | <b>349</b> |



## **sofas**

**Alato  
Brando  
Camillo  
Cloè  
Dante  
Dylan  
Giulia  
Island  
Levante  
Martin  
Penelope  
Savoi  
Sebastian**





## Alato - Pier Luigi Frighetto, 2011



**Modular sofa with structure in metal, with elastic belt spring system stretched over a metal frame. Padding in high-resilience expanded polyurethane, upholstery in thermo-bonded fibre with stretch jersey. Metal armrest padding in high-resilience expanded polyurethane. Seat cushions in 100% European, channelled goose feather, down, closed in independent rooms filling with central insert high-resilience polyurethane foam in different densities and memory foam. Back cushions in 100% European, channelled goose feather, down closed in independent rooms. Fully removable covers in both fabric and leather versions. Feet in shiny stainless steel.**

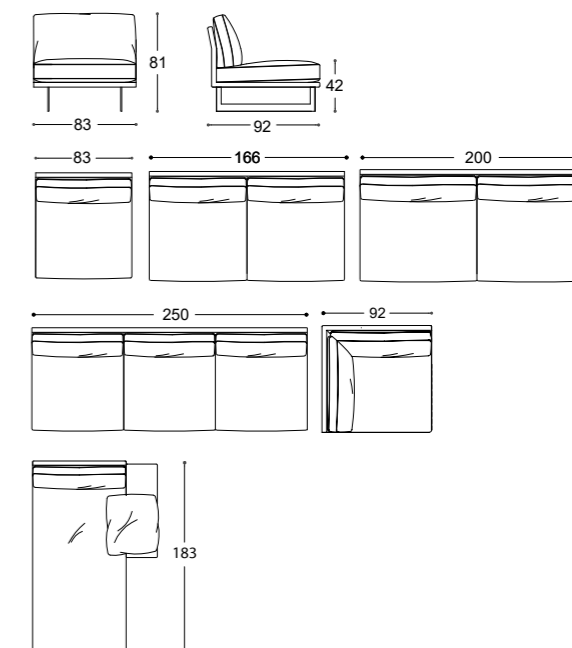









## Brando - Pier Luigi Frighetto, 2014



Sofa with structure in fir and poplar wood, with elastic belt spring system. Padding in high-density expanded polyurethane, upholstery in thermo-bonded fibre with stretch jersey. Seat cushions in 100% European channelled goose feather, 10% down, closed in independent rooms, filling with central insert high-resilience polyurethane foam in different densities and memory foam. Back cushions in 100% European channelled goose feather, 10% down, closed in independent rooms. Fully removable fabric covers, only the cushions for the leather version. Base in metal, dark bronze matt finishing.

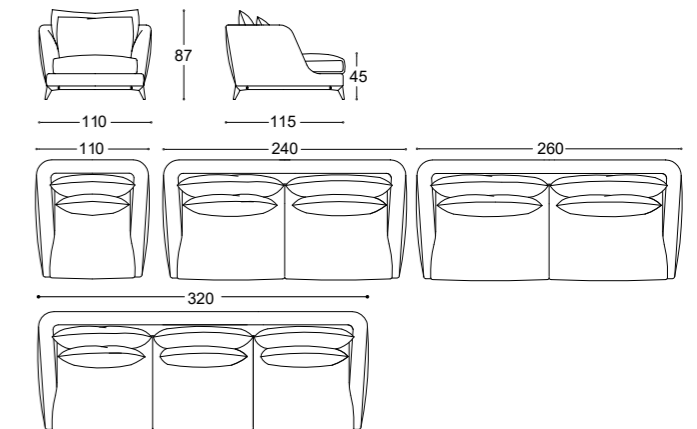













## Camillo - Pier Luigi Frighetto, 2011



**Modular sofa with structure in fir and poplar wood, with crossed elastic belt spring system. Padding in high-density expanded polyurethane, upholstery in thermo-bonded fibre with stretch jersey. Seat cushions in 100% European, channelled goose feather, 10% down, closed in independent rooms, with central insert in memory foam. Back cushions in 100% European, channelled goose feather, 10% down, closed in independent rooms. Fully removable fabric covers, only the cushions for the leather version.**

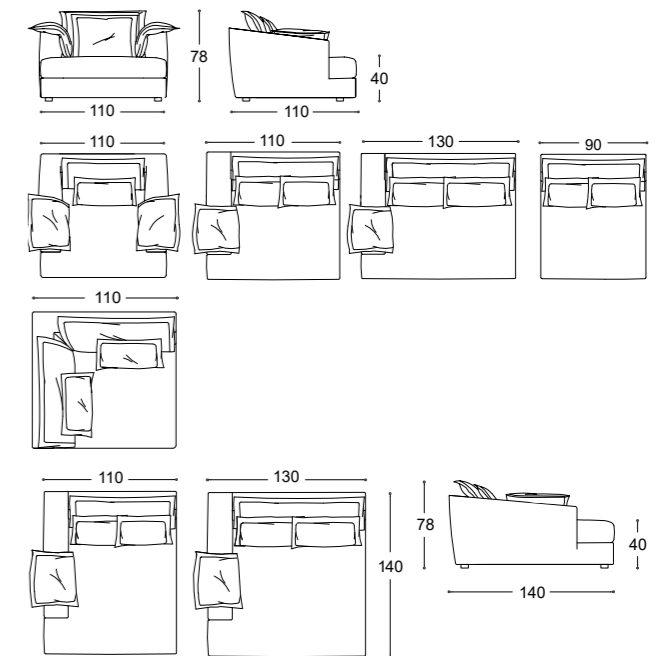









**Cloè sofa- Pier Luigi Frighetto, 2015**



**Sofa with structure in beech wood,  
seat and back in fire-resistant expanded  
polyurethane. Feet upholstered.  
Non-removable cover.**

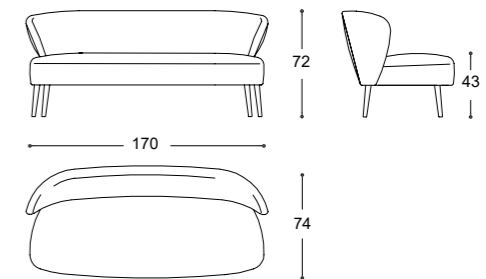





**Dante** - Pier Luigi Frighetto, 2011



Structure in fir and poplar wood, with crossed elastic belt spring system. Padding in high-density expanded polyurethane, upholstery in thermo-bonded fibre with stretch jersey. Seat cushions in 100% European channelled goose feather, 10% down, with central insert in high-density polyurethane, closed in independent rooms. Back cushions in 100% European, channelled goose feather, 10% down, closed in independent rooms, with central insert in memory foam. Fully removable fabric covers, only the cushions for the leather version.

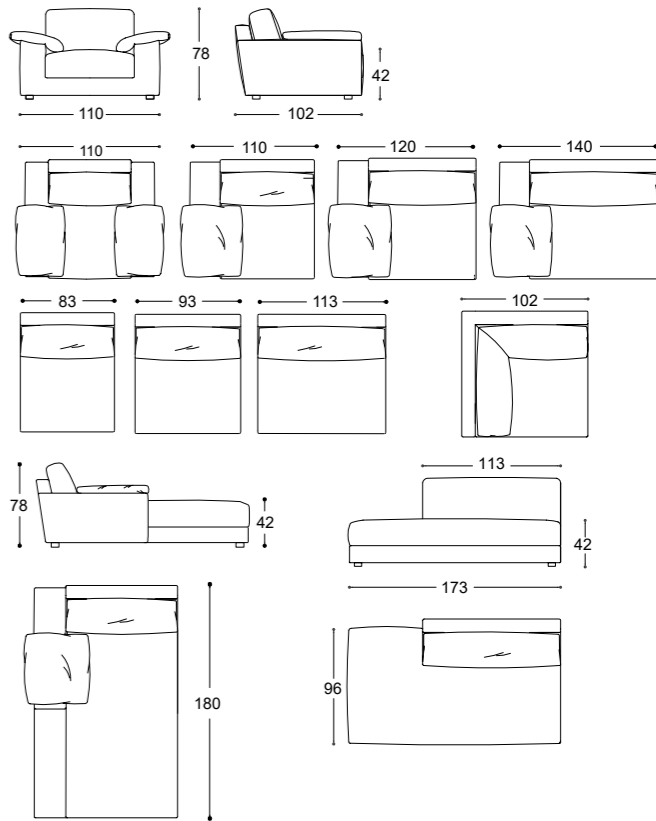













**Giulia sofa** - Pier Luigi Frighetto, 2017



**Sofa with structure in beech wood, seat and back in fire-resistant expanded polyurethane. Metal feet in gold or dark bronze matt galvanic finishing. Removable covers only the cushion.**

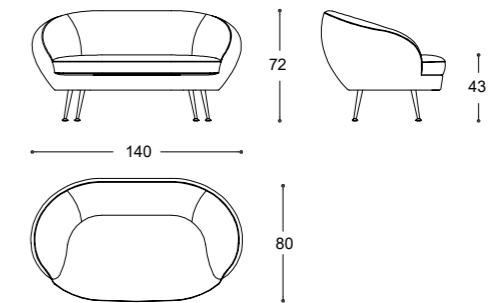





## Island - Pier Luigi Frighetto, 2011



**Modular sofa with structure in fir and poplar wood and metal, with elastic belt spring system stretched over a metal frame. Padding in high-resilience expanded polyurethane, upholstery in thermo-bonded fibre with stretch jersey. Seat and back cushions in 100% European, channelled goose feather, 10% down, closed in independent rooms, filling with central insert in memory foam. Fully removable fabric covers, only the cushion for the leather version. Feet matt dark bronze finishing.**

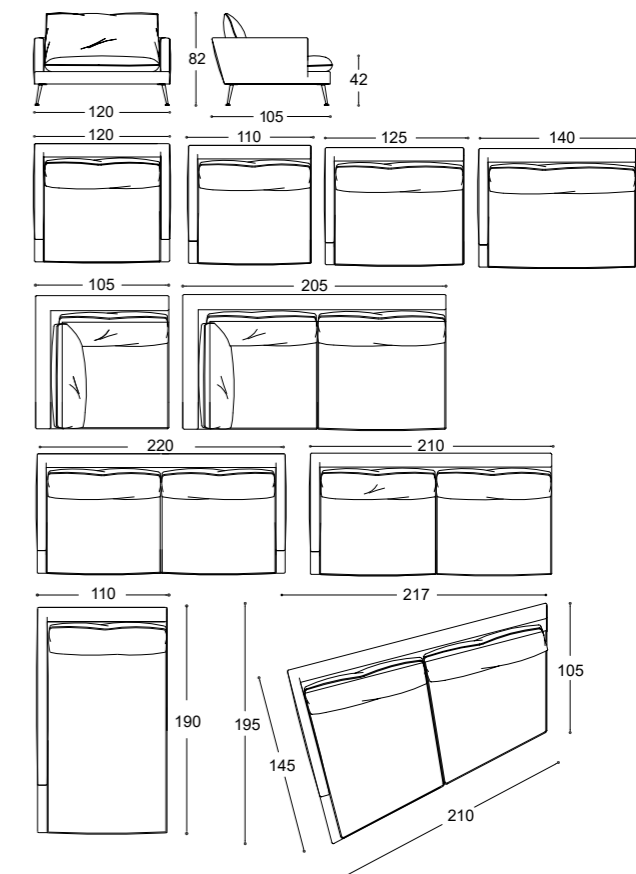

















## Levante - Pier Luigi Frighetto, 2016



Sofa with structure in poplar wood, with crossed elastic belt spring system. Padding in high-density expanded polyurethane, upholstery in thermo-bonded fibre with stretch jersey. Seat cushions in 100% European channelled down feather, closed in independent rooms, filling with central insert high-resilience polyurethane foam in different densities and memory foam. Back cushions in 100% European channelled down feather, closed in independent rooms. Fully removable fabric covers, only the cushions for the leather version.

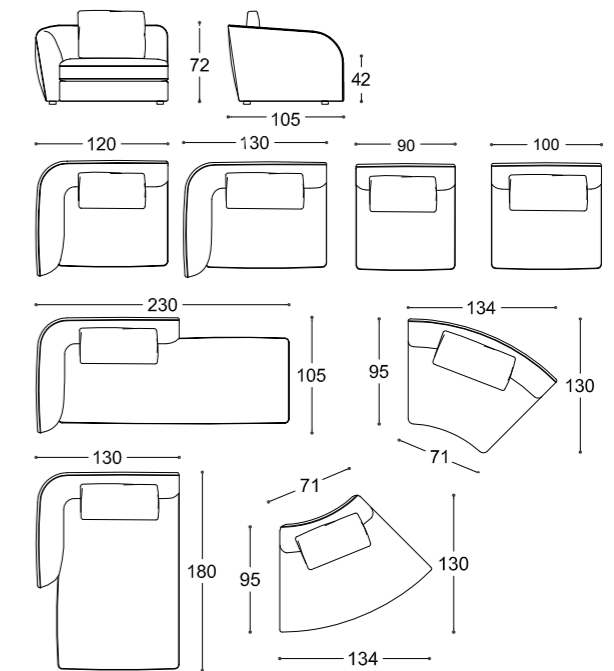

















**Martin** - Pier Luigi Frighetto, 2011



**Modular sofa with structure in fir and poplar wood, with crossed elastic belt spring system. Padding in high-density expanded polyurethane, upholstery in thermo-bonded fibre with stretch jersey. Seat cushions in 100% channelled goose feather, 10% down, closed in independent rooms, filling with central insert high-resilience polyurethane foam in different densities and memory foam. Back cushions in 100% European, channelled goose feather, 10% down, closed in independent rooms. Fully removable fabric covers, only the cushions for the leather version.**

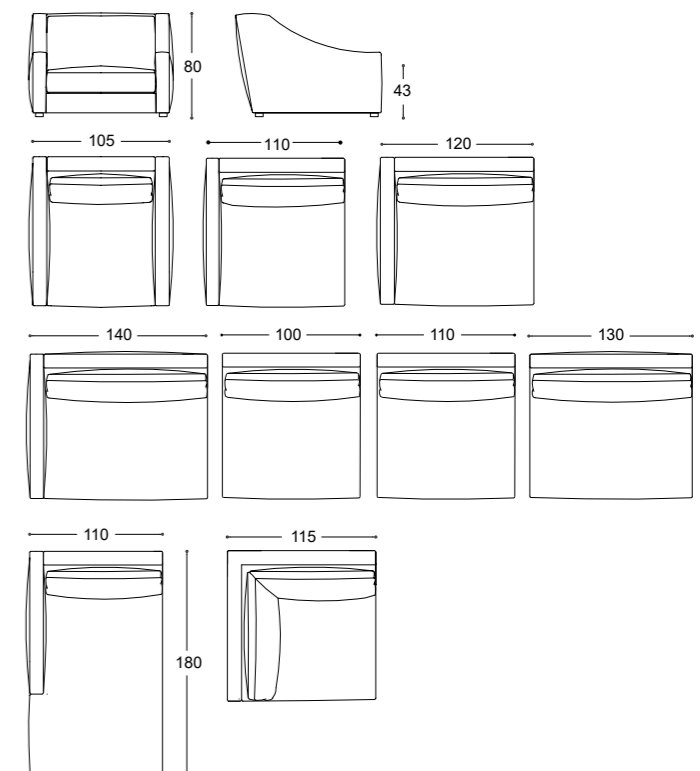













## Penelope - Pier Luigi Frighetto, 2017



Sofa with structure in beech wood, seat and back in fire-resistant expanded polyurethane. Tufted back. Feet upholstered with gold metal glides. Non-removable cover.

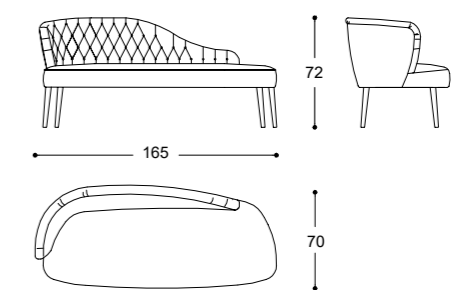





## Savoi sofa - Pier Luigi Frighetto, 2015



Sofa with structure in solid wood, with crossed elastic belt spring system. Padding in high-density expanded polyurethane, upholstery in thermo-bonded fibre with stretch jersey. Seat cushions in 100% European channelled goose feather, 10% down, closed in independent rooms, filling with central insert high-resilience polyurethane foam in different densities and memory foam. Tufted back. Feet upholstered with glides in metal gold finishing. Removable only seat cushions.

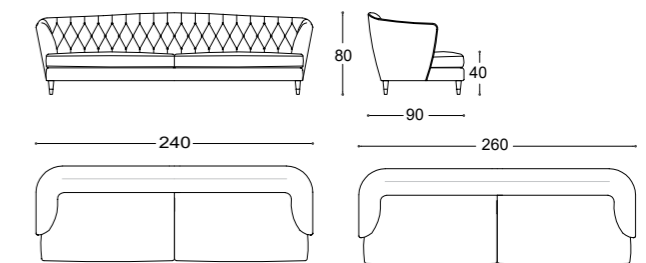









## Sebastian - Pier Luigi Frighetto, 2018



Sofa with structure in poplar wood, with crossed elastic belt spring system.

Padding in high-density expanded polyurethane, upholstery in thermo-bonded fibre with stretch jersey. Seat cushions in 100% European channelled down feather, closed in independent rooms, filling with central insert high-resilience polyurethane foam in different densities and memory foam.

Back cushions in 100% European channelled down feather, closed in independent rooms.

Fully removable fabric covers, only the cushions for the leather version. Feet in metal dark bronze matt finishing.

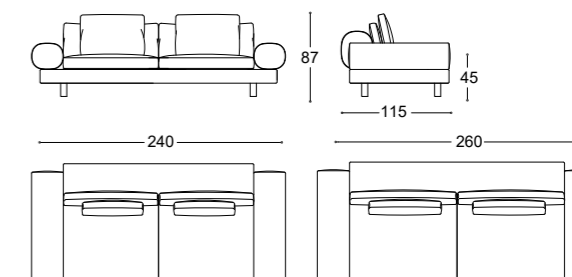







## **armchairs**

**Amelia**

**Anic**

**Cloè**

**Dafne**

**Frisè**

**Giulia**

**Giulia swivel**

**Miranda**

**Savoi**

**Victoria**





**Amelia** - Pier Luigi Frighetto, 2018



**Armchair with structure in beech wood, seat and back in fire-resistant expanded polyurethane. Ash moka lacquered wood base. Non-removable cover.**

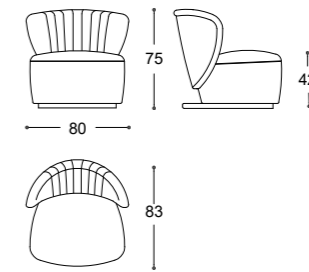





**Anic** - Pier Luigi Frighetto, 2018



Armchair with structure in beech wood, seat and back in fire-resistant expanded polyurethane. Feet upholstered. Non-removable cover.

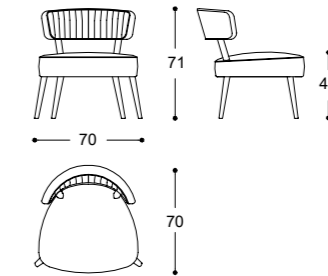





## Cloè - Cloè Gold armchair

Pier Luigi Frighetto, 2014



Armchair with structure in beech wood, seat and back in fire-resistant expanded polyurethane. Feet upholstered. With or without round studs (430). Non-removable cover.

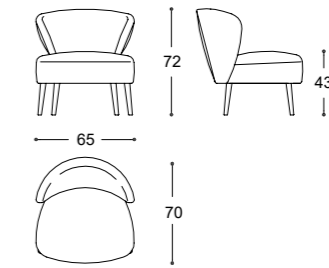





**Dafne** - Pier Luigi Frighetto, 2012



Armchair with structure in beech wood, with crossed elastic belt spring system. Padding in high-density expanded polyurethane. Seat cushions high resilience polyurethane foam in different densities and memory foam. Structure in oil painted Canaletto wood. Non-removable cover.

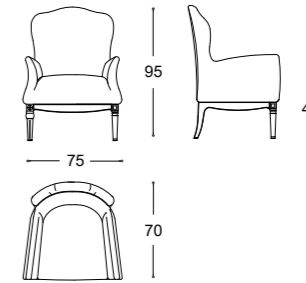





## Frisè - Frisè Chaise Lounge

Beatriz Sempere, 2014



Armchair and chaise lounge with structure in Canaletto walnut solid wood, water-based painted. Seat cushions in 100% European, channelled goose feather, 10% down, closed in independent rooms, filling with central insert high-resilience polyurethane foam in different densities and memory foam. Back cushions in 100% European channelled goose feather, 10% down, closed in independent rooms. Seat body in brown hide, backrest body in hand woven brown hide. Fully removable covers, in both fabric and leather.

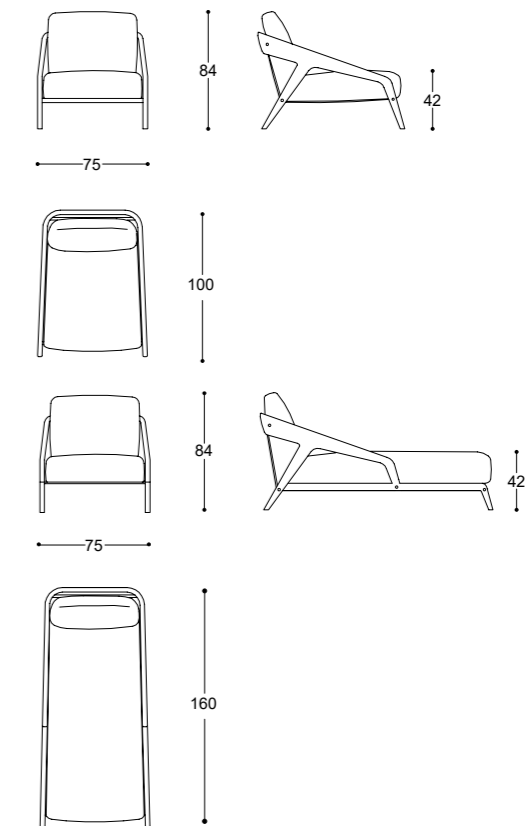









**Giulia armchair** - Pier Luigi Frighetto, 1985



Armchair with structure in beech wood, padding in high-density expanded polyurethane. Seat cushion in high-resilience polyurethane foam. Metal feet in gold or dark bronze matt galvanic finishing. Removable only the cushions.

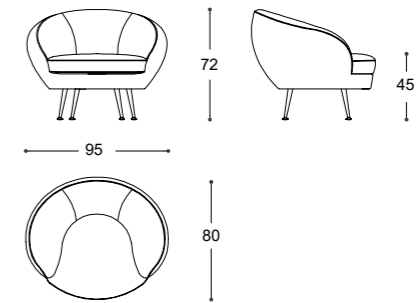





**Giulia swivel** - Pier Luigi Frighetto, 2018



Armchair with structure in beech wood, padding in high-density expanded polyurethane. Seat cushion in high-resilience polyurethane foam. Swivel base (90° left and 90° right with return). Removable cover only the cushions.

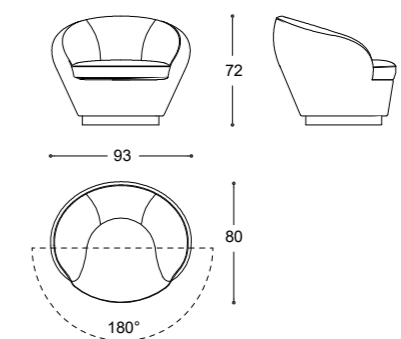





**Miranda** - Pier Luigi Frighetto, 2011



Armchair with structure in fir and poplar wood, with helical steel spring. Padding in high-resilience expanded polyurethane. Seat cushions in 100% European, channelled goose feather, 10% down, closed in independent rooms, filling with central insert high-resilience polyurethane foam in different densities and memory foam. Back cushions in 100% European, channelled goose feather, 10% down, closed in independent rooms. Removable covers in both fabric and leather cushion. Feet in metal oxidize finishing.

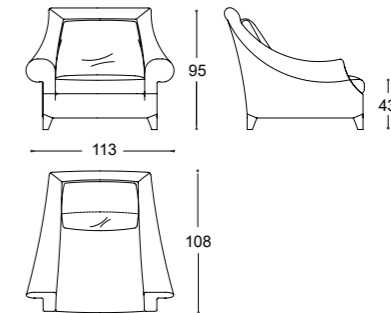





**Savoi armchair-** Pier Luigi Frighetto, 2015



Armchair with structure in solid wood, with crossed elastic belt spring system. Padding in high-resilience expanded polyurethane in different densities. Tufted rear back (optionally). Feet upholstered with glides in metal gold finishing. Non removable cover.

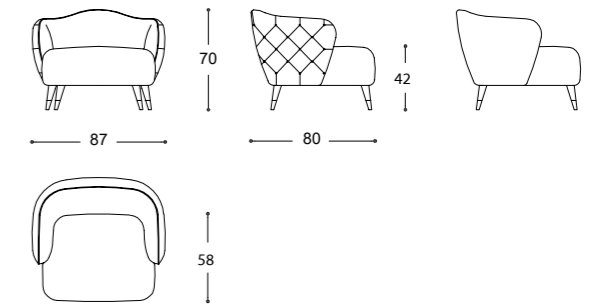







## **chairs and stools**

Cloè  
Kalida  
Olivia





**Cloè dining** - Pier Luigi Frighetto, 2014



Dining chair with structure in beech wood, seat and back in fire-resistant expanded polyurethane. Feet upholstered. Handle in dark bronze matt finishing, optionally. Non-removable cover.

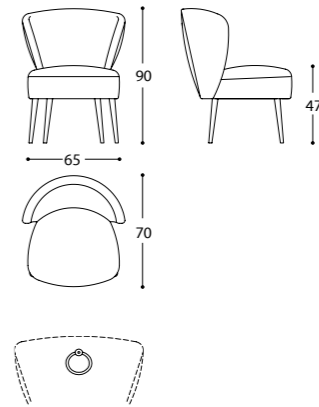





**Kalida dining** - Pier Luigi Frighetto, 2018



Frame in mat black-varnished metal rod. Glides metal polished gold finishing.  
Seat, back in curved beech wood, padding in high-resilience expanded polyurethane.

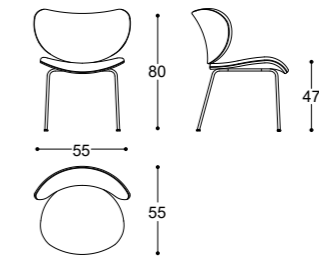









## Olivia dining and stool

Pier Luigi Frighetto, 2016



Dining chair and stool (swivel version available) with structure in solid beech wood, padding in fire-resistant expanded polyurethane. Legs in solid ash, moka lacquered with metal glides and footrest in gold or dark bronze matt finishing.

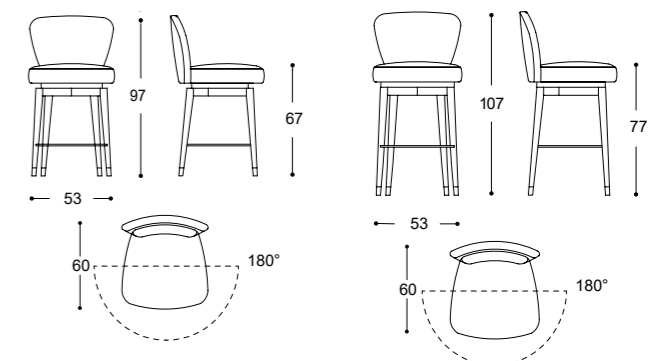
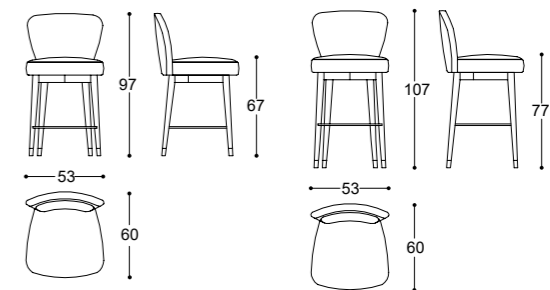
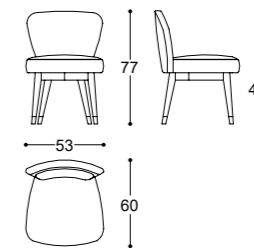











**dining tables**

Santiago





**Santiago** - Beatriz Sempere, 2017



Dining table with supporting structure in birch plywood and top in MDF Canaletto walnut finishing with metal gold finishing parts.

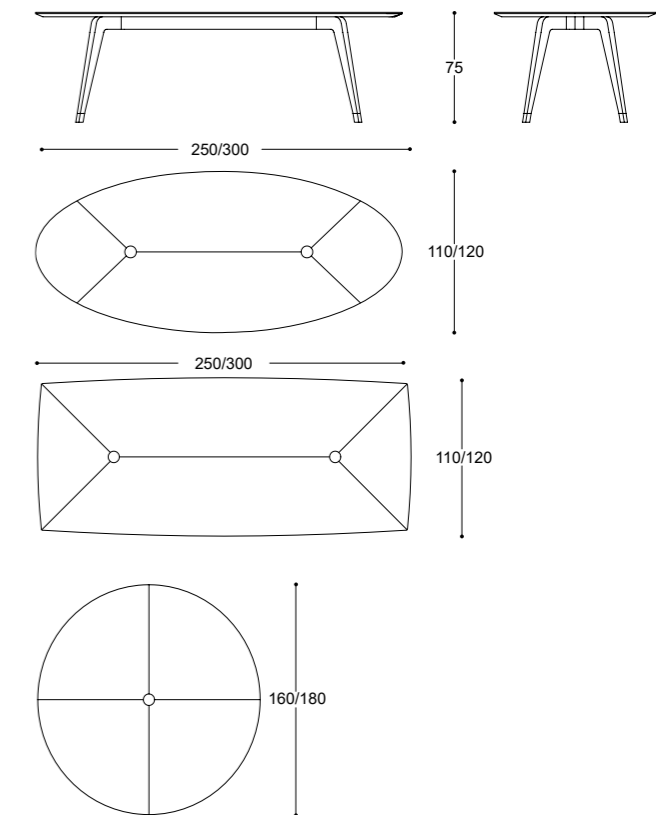

dining tables











## coffee tables

Elliot  
Elliot Plus  
Hugo  
Manolo  
Milton  
Oleg  
Pablo  
Samuel  
Tao  
Tommi





**Elliot** - Pier Luigi Frighetto, 2014



Round tables with structure in metal, dark bronze matt finishing. Top in Elegant Brown stone and Calacatta Vagli Oro. In the small version top in dark bronze matt or polished gold finishing.

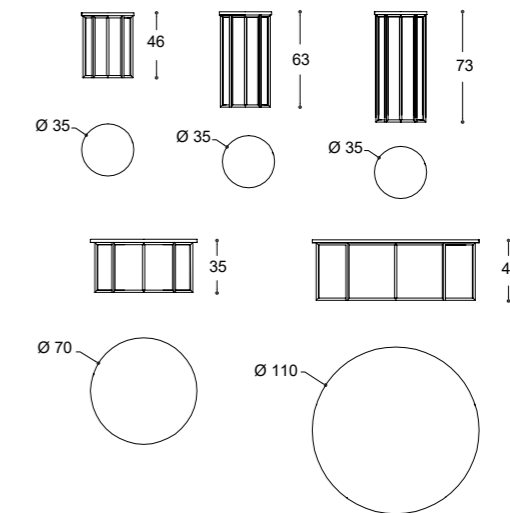





coffee tables





**Elliot Plus** - Pier Luigi Frighetto, 2017



Round side tables with structure in metal, dark bronze matt or gold finishing. Top in Canaletto walnut wood.

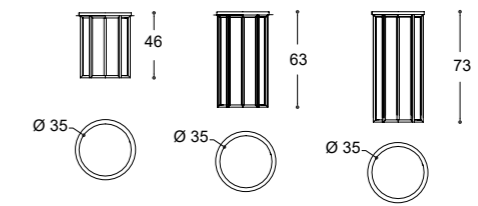









**Hugo** - Pier Luigi Frighetto, 2012



Coffee table with supporting structure in metal, oxidize finishing. Top in Elegant Brown stone or Calacatta marble.

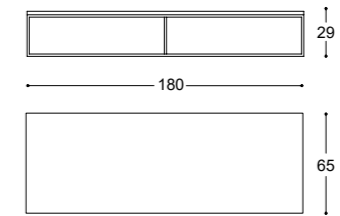





**Milton** - Beatriz Sempere, 2017



Coffee table with supporting structure in birch plywood Canaletto walnut finishing. Top in MDF Canaletto walnut finishing with metal gold finishing glides.

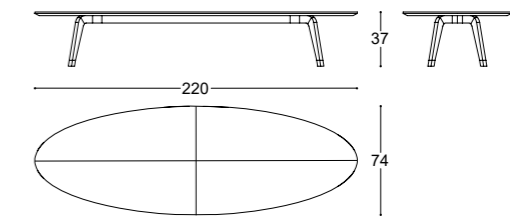





**Oleg** - Pier Luigi Frighetto, 2015



Coffee table with supporting structure in metal dark bronze finishing. Top in MDF Canaletto walnut finishing.

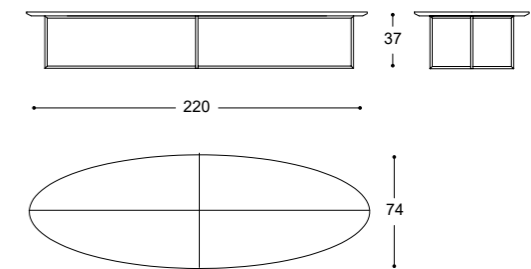





**Pablo** - Pier Luigi Frighetto, 2015



Tables with supporting structure in metal oxidize finishing. Top in Elegant Brown stone or Calacatta Vagli Oro marble.

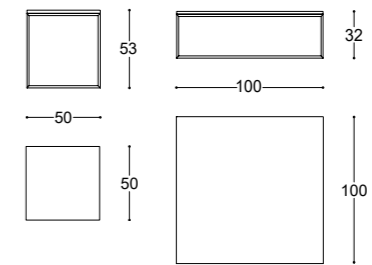





**Samuel** - Pier Luigi Frighetto, 2017



Round tables with structure in metal dark bronze matt finishing. Top in MDF Canaletto walnut finishing.

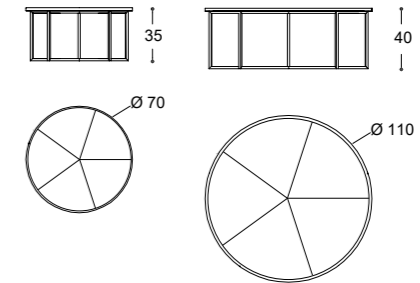









**Tao** - A-latere Collateral Design, 2017



Small table with structure instainless steel polished gold, back lacquered glass top, green, red, dark blue.

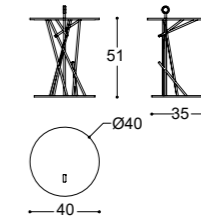



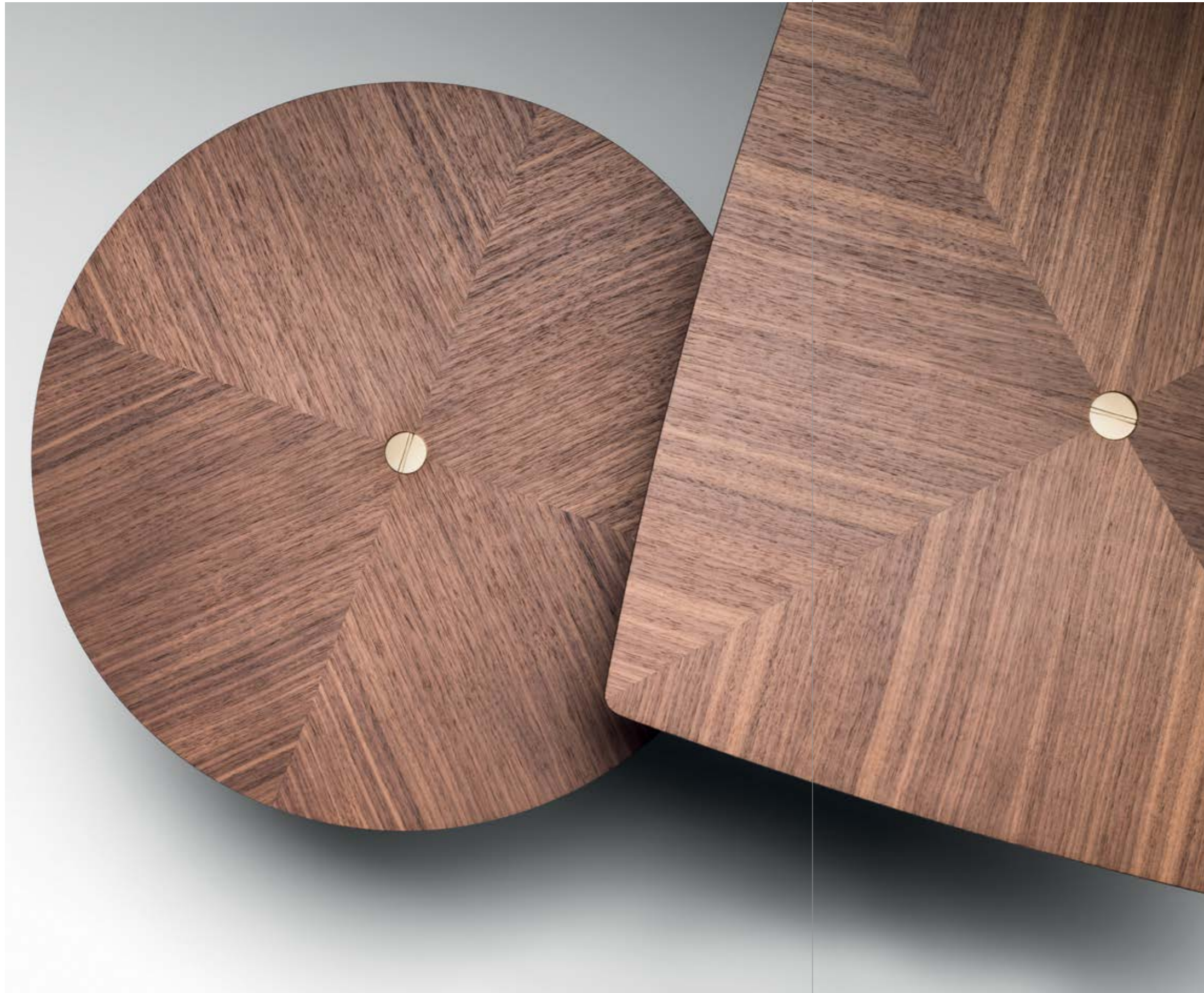

**Tommi tables** - Beatriz Sempere, 2015



**Side tables and consoles with supporting structure in Canaletto walnut solid wood.**

**Top in MDF Canaletto walnut finishing with central insert in metal gold finishing.**

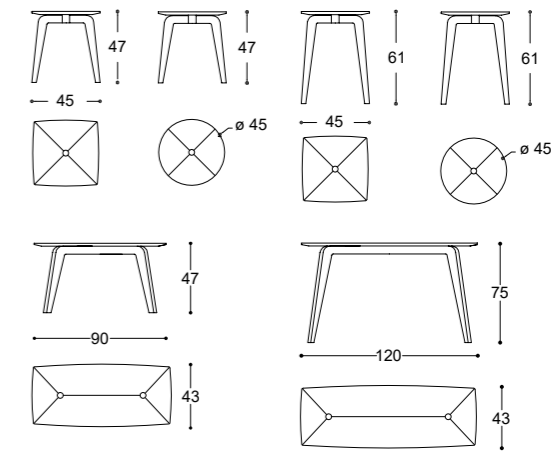







## ottomans and benches

Casablanca  
Cubo  
Olivia  
Rondò  
Savoi  
Timoty  
Tommi





**Casablanca** - Pier Luigi Frighetto, 2011



**Pouf with structure in multi-layered poplar. Padding in high-resilience polyurethane foam in different densities. Upper padding 100% European feather. Hand-sewn leather cover. Non removable cover.**

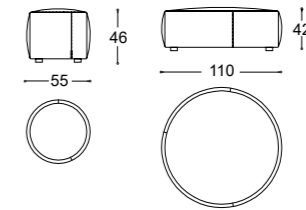





**Cubo** - Pier Luigi Frighetto, 2011



**Pouf collection with structure in multi-layered poplar. Padding in high-resilience expanded polyurethane, covered with 100% European channelled goose feather. Fully removable cover in fabric, non-removable in leather version.**

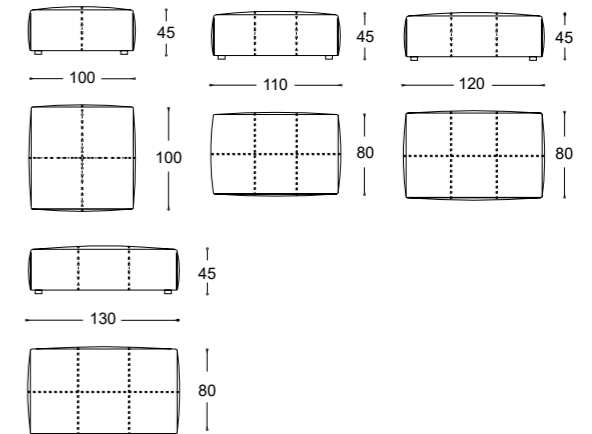





**Olivia bench** - Pier Luigi Frighetto, 2016



**Bench with structure in solid beech wood. Padding in high resilience polyurethane foam. Non-removable cover. Legs in solid ash, moka lacquered with metal glides.**

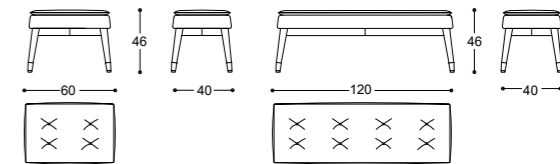





**Rondò** - Pier Luigi Frighetto, 2011



**Pouf collection with structure in multi-layered poplar. Padding in high-resilience polyurethane foam in different densities and memory foam. Upper padding 100% European, goose feather. Fully removable fabric cover. Non-removable leather cover.**

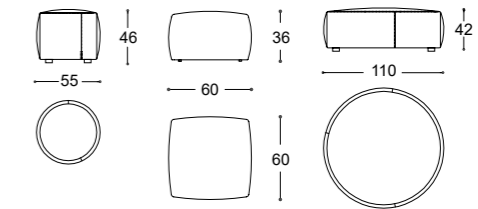





**Savoï bench** - Pier Luigi Frighetto, 2015



**Pouf with structure in fir and poplar wood. Padding in high-resilience polyurethane foam in different densities. Deep, button-padded upholstery, non removable cover. Feet upholstered with glides metal polished gold finishing.**

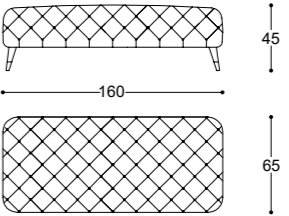



**beds**

Savoi





**Savoi bed** - Pier Luigi Frighetto, 2015



Headboard and bed frame in poplar wood, padding in high-density expanded polyurethane, upholstery in thermo-bonded fibre with stretch jersey. Capitonè upholstered headboard in polyurethane foam in different densities. Wooden slatted base. Feet upholstered with glides in metal gold finishing. Non-removable cover.

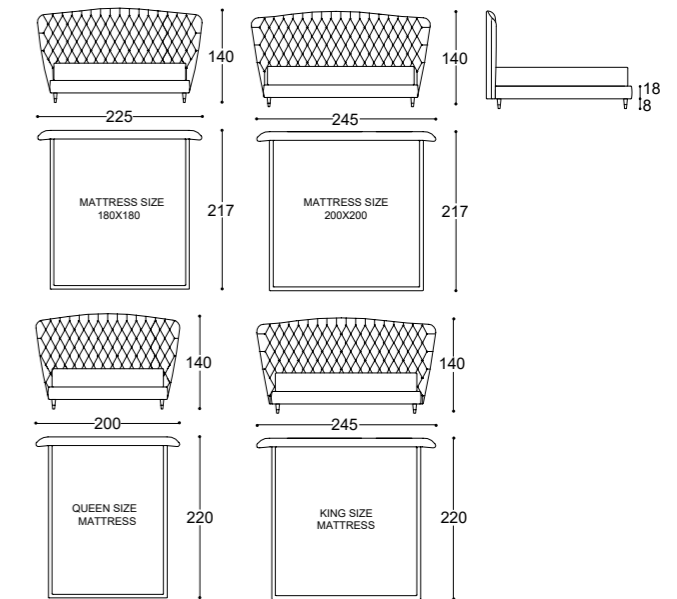

beds



## **lighting**

**Diva  
Maite  
Nadine  
Thelma  
Tosca**





**Diva** - Black Tie Studio, 2018



Table lamp for diffused or downward lighting with central body in Emperador marble, metal elements dark bronze matt finishing. Brown lampshade. Light source: 2XE27 (Led bulbs suggested).

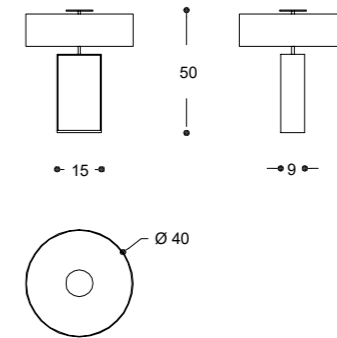





**Nadine** - Black Tie Studio, 2015



Table lamp for diffused or downward lighting. Wood base dark blue lacquered, metal elements polished gold. Brown lampshade, internal black cottonette. Light source: 2XE27 (Led bulbs suggested).

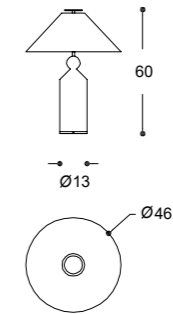





**Thelma** - Black Tie Studio, 2015



Table lamp for diffused or downward lighting with central body in Carrara marble, metal elements polished gold. White lampshade. Light source: 2XE27 (Led bulbs suggested).

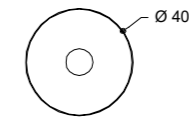
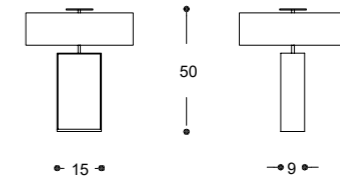





**Tosca** - Black Tie Studio, 2015



Floor lamp for diffused or downward lighting. Wood base dark blue lacquered, metal elements polished gold. Dark blue lampshade, internal black cottonette. Light source: 2XE27 (Led bulbs suggested).

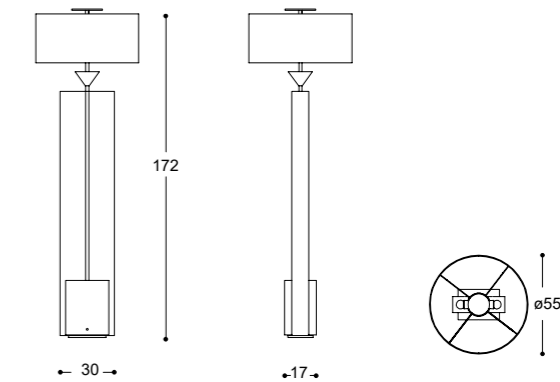



## accessories

Aliseo  
Mou





**Aliseo** - Marco Corti, 2014



Room divider with structure in multi-layered poplar, padding in high-resilience expanded polyurethane, upholstered in fabric. Metal frame polished gold finishing.

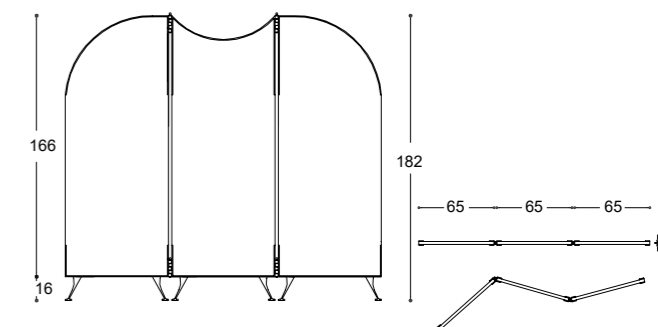

accessories





**MOU** - Beatriz Sempere, 2016



**Mirror with structure in black MDF, frame in laser cut metal, dark bronze finishing. Silver, silver bronze, silver grey mirrored glass. Wall mount brackets.**

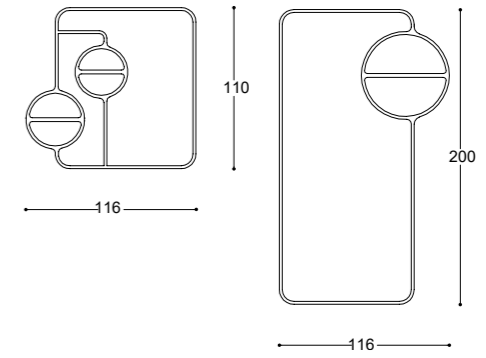



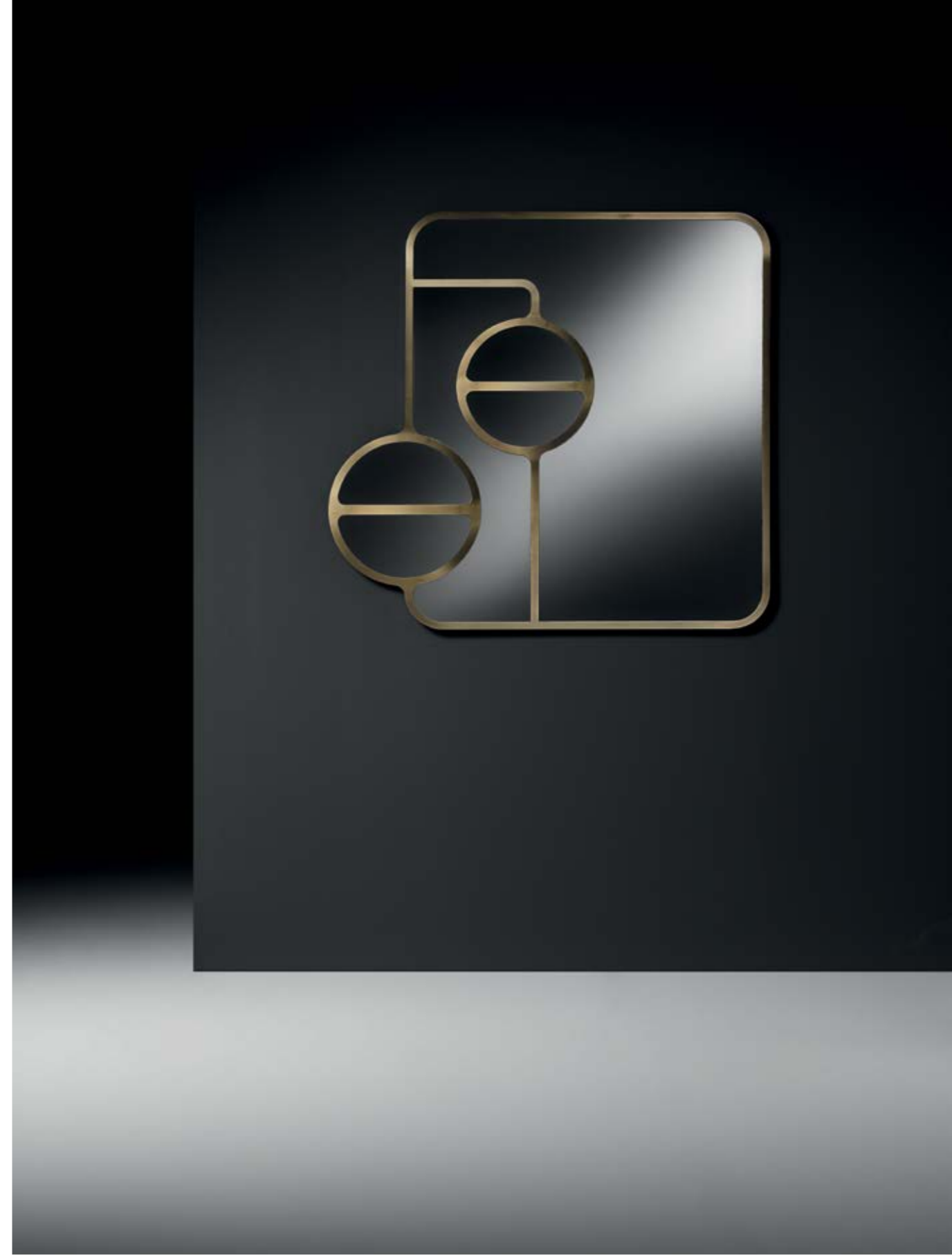



Editor and Art Direction / Black Tie  
Concept and Graphic / Diamante Beghetto  
Interior decoration / Barbara Marsiletti  
Photo ambiances / Emanuele Tortora  
Still life / Varianti fotografia  
Artworks / Diamante Beghetto  
Copywriting / Irene Pollini Giolai  
Print / GRAFICART Arti Grafiche - April 2018  
Special Thanks to / Alpes Inox srl, Studioart Leather Interiors srl

-

Black Tie srl reserves the right to change,  
at any time and without prior warning,  
the technical specification of any product  
illustrated in this catalogue.

-

No part of this publication may be reproduced  
in any form or by any means without  
prior permission in writing from Black Tie srl  
Copyright Black Tie srl. All rights reserved

For further information  
please visit our website - [www.blacktiesofas.it](http://www.blacktiesofas.it)  
Follow us on: Facebook, Instagram, You Tube

Black Tie srl  
Via Valchiampo, 54  
36050 Montorso Vicentino (VI) Italy  
Tel. +39 0444 453009  
Fax +39 0444 1833546  
[blacktie@blacktiesofas.it](mailto:blacktie@blacktiesofas.it)



